

STAINLESS STEEL CABINETS



Stainless Steel Kitchen Cabinets

Technical Specification

Hinge Options	110° zinc plated steel hinges- soft closing
Standard	Snap-on function; make it easy to remove the door for cleaning
Door/Drawer Panels	Manufactured from brushed stainless steel, 430 grade.
Finish Upgrade	The stainless steel panels can be powder coated to any colour, please specify the RAL colour when ordering.
Drawer Mechanism	Integrated damper that catches the running drawers so that they close slowly, silently and softly. Fully-extending drawers; for easy overview and access to the contents. Smooth-running drawers with stop. Drawers are self-closing the last few centimetres. Powder Coated steel- Colour Silver
Pan Drawer Mechanism	Integrated damper that catches the running drawers so that they close slowly, silently and softly. Fully-extending drawers; for easy overview and access to the contents. Smooth-running drawers with stop. Drawers are self-closing the last few centimetres. Powder Coated steel- Colour Silver
Carcase	Sturdy frame construction, brushed stainless steel, 430 grade.
Handles	All cabinets are supplied as standard with a brushed steel 'T' bar handle (code- H01) other styles & lengths are available upon request.



Stainless Steel Cabinets- 500mm Depth Range Summary



Base Units

Base Cupboard Units- Full Height Door(s) 1# Internal Shelf								
C35 L/R Single Door	C45 L/R Single Door	C45S L/R Single Door	C55 L/R Single Door	C65 L/R Single Door	C85 Double Door	C95 Double Door	C105 Double Door	C125 Double Door
W300 x D500 x H882	W400 x D500 x H882	W450 x D500 x H882	W500 x D500 x H882	W600 x D500 x H882	W800 x D500 x H882	W900 x D500 x H882	W1000 x D500 x H882	W1200 x D500 x H882

Base Cupboard Sink Units- Full Height Door(s)								
C35S L/R Single Door	C45S L/R Single Door	C45SS L/R Single Door	C55S L/R Single Door	C65S L/R Single Door	C85S Double Door	C95S Double Door	C105S Double Door	C125S Double Door
W300 x D500 x H882	W400 x D500 x H882	W450 x D500 x H882	W500 x D500 x H882	W600 x D500 x H882	W800 x D500 x H882	W900 x D500 x H882	W1000 x D500 x H882	W1200 x D500 x H882

Drawerline Units- Drawer(s) and Door(s) 1# Internal Shelf								
D35 L/R Single Drawer/Door	D45 L/R Single Drawer/Door	D45S L/R Single Drawer/Door	D55 L/R Single Drawer/Door	D65 L/R Single Drawer/Door	D85 Double Drawer/Door	D95 Double Drawer/Door	D105 Double Drawer/Door	D125 Double Drawer/Door
W300 x D500 x H882	W400 x D500 x H882	W450 x D500 x H882	W500 x D500 x H882	W600 x D500 x H882	W800 x D500 x H882	W900 x D500 x H882	W1000 x D500 x H882	W1200 x D500 x H882

Drawerline Sink Units- Drawer(s) and Door(s)								
D35S L/R False Drawer	D45S L/R False Drawer	D45SS L/R False Drawer	D55S L/R False Drawer	D65S L/R False Drawer	D85S False Drawers	D95S False Drawers	D105S False Drawers	D125S False Drawers
W300 x D500 x H882	W400 x D500 x H882	W450 x D500 x H882	W500 x D500 x H882	W600 x D500 x H882	W800 x D500 x H882	W900 x D500 x H882	W1000 x D500 x H882	W1200 x D500 x H882

Base Open Shelving Units- 3No. Internal Shelves								
BO35 Open Shelving	BO45 Open Shelving	BO44S Open Shelving	BO55 Open Shelving	BO65 Open Shelving	BO85 Open Shelving	BO95 Open Shelving	BO105 Open Shelving	BO125 Open Shelving
W300 x D500 x H882	W400 x D500 x H882	W450 x D500 x H882	W500 x D500 x H882	W600 x D500 x H882	W800 x D500 x H882	W900 x D500 x H882	W1000 x D500 x H882	W1200 x D500 x H882

Base Sink Open Shelving Units- 1No. Base Shelf								
BO35S Open Shelving	BO45S Open Shelving	BO44SS Open Shelving	BO55S Open Shelving	BO65S Open Shelving	BO85S Open Shelving	BO95S Open Shelving	BO105S Open Shelving	BO125S Open Shelving
W300 x D500 x H882	W400 x D500 x H882	W450 x D500 x H882	W500 x D500 x H882	W600 x D500 x H882	W800 x D500 x H882	W900 x D500 x H882	W1000 x D500 x H882	W1200 x D500 x H882

Base Cupboard Corner Units- Full Height Doors			
C85C L/R Double Door	C95C L/R Double Door	C105C L/R Double Door	C125C L/R Double Door
W800 x D500 x H882	W900 x D500 x H882	W1000 x D500 x H882	W1200 x D500 x H882

Base Cupboard Sink Corner Units- Full Height Doors			
C85SC L/R Single Door	C95SC L/R Single Door	C105SC L/R Single Door	C125SC L/R Single Door
W800 x D500 x H882	W900 x D500 x H882	W1000 x D500 x H882	W1200 x D500 x H882

Drawerline Corner Units			
D85C L/R Single Door/Drawer	D95C L/R Single Door/Drawer	D105C L/R Single Door/Drawer	D125C L/R Single Door/Drawer
W800 x D500 x H882	W900 x D500 x H882	W1000 x D500 x H882	W1200 x D500 x H882

Drawerline Sink Corner Units			
D85SC L/R False Drawer	D95SC L/R False Drawer	D105SC L/R False Drawer	D125SC L/R False Drawer
W800 x D500 x H882	W900 x D500 x H882	W1000 x D500 x H882	W1200 x D500 x H882

Base Cupboard Corner Units- Full Height Doors			
BO85C L/R Open Shelving	BO95C L/R Open Shelving	BO105C L/R Open Shelving	BO125C L/R Open Shelving
W800 x D500 x H882	W900 x D500 x H882	W1000 x D500 x H882	W1200 x D500 x H882

Base Cupboard Sink Corner Units- Full Height Doors			
BO85SC L/R Open Shelving	BO95SC L/R Open Shelving	BO105SC L/R Open Shelving	BO125SC L/R Open Shelving
W800 x D500 x H882	W900 x D500 x H882	W1000 x D500 x H882	W1200 x D500 x H882

L Shaped Corner
C88C L/R Bi-Folding Door
W835/835 x D500 x H882

L Shaped Corner
C88SC L/R Bi-Folding Door
W835/835 x D500 x H882









L Shaped Corner
D88C L/R Bi-Folding Door
W835/835 x D500 x H882









L Shaped Corner
D88SC L/R Bi-Folding Door
W835/835 x D500 x H882









L Shaped Corner
BO88C L/R Open Shelving
W835/835 x D500 x H882

L Shaped Corner
BO88SC L/R Open Shelving
W835/835 x D500 x H882





Drawer Pack Units

Drawer Pack Units- 2No. Drawers								
DD35-2 Pan Drawers	DD45-2 Pan Drawers	DD455-2 Pan Drawers	DD55-2 Pan Drawers	DD65-2 Pan Drawers	DD85-2 Pan Drawers	DD95-2 Pan Drawers	DD105-2 Pan Drawers	DD125-2 Pan Drawers
								
W300 x D500 x H882	W400 x D500 x H882	W450 x D500 x H882	W500 x D500 x H882	W600 x D500 x H882	W800 x D500 x H882	W900 x D500 x H882	W1000 x D500 x H882	W1200 x D500 x H882





Drawer Pack Units- 3No. Drawers								
DD35-3 Drawer + Pan Drawer	DD45-3 Drawer + Pan Drawer	DD455-3 Drawer + Pan Drawer	DD55-3 Drawer + Pan Drawer	DD65-3 Drawer + Pan Drawer	DD85-3 Drawer + Pan Drawer	DD95-3 Drawer + Pan Drawer	DD105-3 Drawer + Pan Drawer	DD125-3 Drawer + Pan Drawer
								
W300 x D500 x H882	W400 x D500 x H882	W450 x D500 x H882	W500 x D500 x H882	W600 x D500 x H882	W800 x D500 x H882	W900 x D500 x H882	W1000 x D500 x H882	W1200 x D500 x H882





Drawer Pack Units- 4No. Drawers								
DD35-4 4 No. Drawers	DD45-4 4 No. Drawers	DD455-4 4 No. Drawers	DD55-4 4 No. Drawers	DD65-4 4 No. Drawers	DD85-4 4 No. Drawers	DD95-4 4 No. Drawers	DD105-4 4 No. Drawers	DD125-4 4 No. Drawers
								
W300 x D500 x H882	W400 x D500 x H882	W450 x D500 x H882	W500 x D500 x H882	W600 x D500 x H882	W800 x D500 x H882	W900 x D500 x H882	W1000 x D500 x H882	W1200 x D500 x H882





Base Bin Units







Base Bin Housing Units			
CB30-50/ECS30 Pull out Bin- 40Ltr	CB45-50/TM45 Tilt Mechanism- 40Ltr	CB45-50/ECS45 Pull Out Bins- 2x 19Ltr	CB60-50/ECS60 Pull Out Bins- 2x 30Ltr
			
W300 x D500 x H882	W450 x D500 x H882	W450 x D500 x H882	W600 x D500 x H882

Appliance Housing Units





Appliance Housings Base Units- Ovens			
D65-H	D65-HD	D95-H	D95-HD
W570 Aperature	Oven H'sing + Drawer	W570 Aperature	Oven H'sing + Drawer
			
W600 x D500 x H882	W600 x D500 x H882	W600 x D500 x H882	W900 x D500 x H882





Mid Height Appliance Housing Units			
MH65-D	MH65-S	MH65-F L/R	MH65-C L/R
W570 x H885 Aperature	W570 x H888 Aperature	W570 x H590 Aperature	W570 x H590 Aperature
			
W600 x D500 x H1325	W600 x D500 x H1325	W600 x D500 x H1325	W600 x D500 x H1325

Tall Appliance Housing Units- Fridge/Freezers					
TH65F-A L/R	TH65F-B L/R	TH65F-BB L/R	TH65-C L/R	TH65F-D L/R	TH65F-E L/R
Fridge/Freezer Spec	Fridge/Freezer Spec	Fridge/Freezer Spec	Fridge/Freezer Spec	Fridge/Freezer Spec	Fridge/Freezer Spec
W538 x D533 x H1772	W541 x D542 x H874	X2 W541 x D542 x H874	W541 x D542 x H1021	W541 x D542 x H1221	W541 x D545 x H1578
					
W600 x D550 x H2092	W600 x D550 x H2092	W600 x D550 x H2092	W600 x D550 x H2092	W600 x D550 x H2092	W600 x D550 x H2092

Tall Appliance Housings- Ovens/Microwaves						
TH65M-C L/R	TH65M-DD L/R	TH65SO-C L/R	TH65SO-DD PAN	TH65DO-C L/R	TH65DO L/R	TH65DO-D L/R
Microwave/Oven H'sing	Microwave/Oven H'sing	Oven Housing	Oven Housing	Doublet Oven Housing	Doublet Oven Housing	Doublet Oven Housing
W568 x H598 Aperature	W568 x H598 Aperature	W568 x H598 Aperature	W568 x H598 Aperature	W560 x H888 Aperature	W560 x H888 Aperature	W560 x H888 Aperature
						
W600 x D550 x H2092	W600 x D550 x H2092	W600 x D550 x H2092	W600 x D550 x H2092	W600 x D550 x H2092	W600 x D550 x H2092	W600 x D550 x H2092







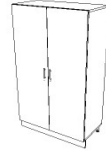
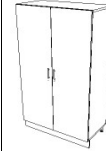
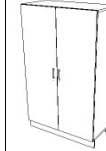

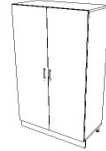
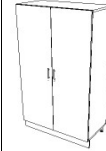
Tall Larder Units

Larder Units- Single Hinged Door, 6# Internal Shelves			
L35 L/R	L45 L/R	L55 L/R	L65 L/R
Single Hinged Door	Single Hinged Door	Single Hinged Door	Single Hinged Door
			
W300 x D500 x H882	W400 x D400 x H882	W450 x D500 x H882	W500 x D500 x H882









Larder Units- Single Hinged Door, Pull out Mechanism			
L35-P	L45-P	L55-P	L65-P
Single Pull Door	Single Pull Door	Single Pull Door	Single Pull Door
			
W300 x D500 x H882	W400 x D400 x H882	W450 x D500 x H882	W500 x D500 x H882





Larder- Double Door, 6# Internal Shelves			
L85	L95	L105	L125
Double Hinged Door	Double Hinged Door	Double Hinged Door	Double Hinged Door
			
W800 x D550 x H2092	W900 x D500 x H2092	W1000 x D500 x H2092	W1200 x D500 x H2092

Chefs Pantry	
L95-CP	L105-CP
Double Hinged Door	Double Hinged Door
	
W900 x D500 x H2092	W1000x D500 x H2092

Top Boxes									
TB35	TB45	TB455	TB55	TB65	TB85	TB95	TB105	TB125	
Lift Up Door Mechanism	Lift Up Door Mechanism	Lift Up Door Mechanism	Lift Up Door Mechanism	Lift Up Door Mechanism	Lift Up Door Mechanism	Lift Up Door Mechanism	Lift Up Door Mechanism	Lift Up Door Mechanism	Lift Up Door Mechanism
									
W300 x D500 x H882	W400 x D500 x H882	W450 x D500 x H882	W500 x D500 x H882	W600 x D500 x H882	W800 x D500 x H882	W900 x D500 x H882	W1000 x D500 x H882	W1200 x D500 x H882	





Wall Cupboard Units

Wall Cupboards- 300mm High								
W33 L/R	W43 L/R	W453 L/R	W53 L/R	W63 L/R	W83	W93	W103	W123
Single Hinged Door	Single Hinged Door	Single Hinged Door	Single Hinged Door	Single Hinged Door	Double Hinged Door	Double Hinged Door	Double Hinged Door	Double Hinged Door
								
W300 x D325 x H300	W400 x D325 x H300	W450 x D325 x H300	W500 x D325 x H300	W600 x D325 x H300	W800 x D325 x H300	W900 x D325 x H300	W1000 x D325 x H300	W1200 x D325 x H300

Wall Cupboard, Straight Corner Unit- Single Door H300			
W83C L/R	W93C L/R	W103C L/R	W123C L/R
Single Hinged Door	Single Hinged Door	Single Hinged Door	Single Hinged Door
			
W800 x D325 x H300	W900 x D325 x H300	W1000 x D325 x H300	W1200 x D325 x H300





W L Corner
W83LC L/R
Bi-Folding Door

W835/835 x D325 x H300

Wall Cupboards- 600mm High, 1# Internal Adjustable Height Shelf								
W36 L/R	W46 L/R	W456 L/R	W56 L/R	W66 L/R	W86	W96	W106	W126
Single Hinged Door	Single Hinged Door	Single Hinged Door	Single Hinged Door	Single Hinged Door	Double Hinged Door	Double Hinged Door	Double Hinged Door	Double Hinged Door
								
W300 x D325 x H600	W400 x D325 x H600	W450 x D325 x H600	W500 x D325 x H600	W600 x D325 x H600	W800 x D325 x H600	W900 x D325 x H600	W1000 x D325 x H600	W1200 x D325 x H600

Wall Cupboard, Straight Corner Unit- Single Door H600			
W86C L/R	W96C L/R	W106C L/R	W126C L/R
Single Hinged Door	Single Hinged Door	Single Hinged Door	Single Hinged Door
			
W800 x D325 x H600	W900 x D325 x H600	W1000 x D325 x H600	W1200 x D325 x H600





W L Corner
W86LC L/R
Bi-Folding Door

W835/835 x D325 x H600

Wall Cupboards- 720mm High, 1# Internal Adjustable Height Shelf								
W37 L/R	W47 L/R	W457 L/R	W57 L/R	W67 L/R	W87	W97	W107	W127
Single Hinged Door	Single Hinged Door	Single Hinged Door	Single Hinged Door	Single Hinged Door	Double Hinged Door	Double Hinged Door	Double Hinged Door	Double Hinged Door
								
W300 x D325 x H720	W400 x D325 x H720	W450 x D325 x H720	W500 x D325 x H720	W600 x D325 x H720	W800 x D325 x H720	W900 x D325 x H720	W1000 x D325 x H720	W1200 x D325 x H720

Wall Cupboard, Straight Corner Unit- Single Door H720			
W87C L/R	W97C L/R	W107C L/R	W127C L/R
Single Hinged Door	Single Hinged Door	Single Hinged Door	Single Hinged Door
			
W800 x D325 x H720	W900 x D325 x H720	W1000 x D325 x H720	W1200 x D325 x H720

W L Corner
W87LC L/R
Bi-Folding Door

W835/835 x D325 x H720







Wall Cupboards- 900mm High, 2# Internal Adjustable Height Shelf								
W39 L/R	W49 L/R	W459 L/R	W59 L/R	W69 L/R	W89	W99	W109	W129
Single Hinged Door	Single Hinged Door	Single Hinged Door	Single Hinged Door	Single Hinged Door	Double Hinged Door	Double Hinged Door	Double Hinged Door	Double Hinged Door
								
W300 x D325 x H900	W400 x D325 x H900	W450 x D325 x H900	W500 x D325 x H900	W600 x D325 x H900	W800 x D325 x H900	W900 x D325 x H900	W1000 x D325 x H900	W1200 x D325 x H900

Wall Cupboard, Straight Corner Unit- Single Door H900			
W89C L/R	W99C L/R	W109C L/R	W129C L/R
Single Hinged Door	Single Hinged Door	Single Hinged Door	Single Hinged Door
			
W800 x D325 x H900	W900 x D325 x H900	W1000 x D325 x H900	W1200 x D325 x H900









W L Corner
W89LC L/R
Bi-Folding Door



W835/835 x D325 x H900





Wall Display Units

Wall Open Shelving Unit- 300mm High								
WO33 Open Unit	WO43 Open Unit	WO453 Open Unit	WO53 Open Unit	WO63 Open Unit	WO83 Open Unit	WO93 Open Unit	WO103 Open Unit	WO123 Open Unit
								
W300 x D325 x H300	W400 x D325 x H300	W450 x D325 x H300	W500 x D325 x H300	W600 x D325 x H300	W800 x D325 x H300	W900 x D325 x H300	W1000 x D325 x H300	W1200 x D325 x H300





Wall Open Shelving Unit- 600mm High, 1# Internal Adjustable Height Shelf								
WO36 1# Internal Shelf	WO46 1# Internal Shelf	WO456 1# Internal Shelf	WO56 1# Internal Shelf	WO66 1# Internal Shelf	WO86 1# Internal Shelf	WO96 1# Internal Shelf	WO106 1# Internal Shelf	WO126 1# Internal Shelf
								
W300 x D325 x H600	W400 x D325 x H600	W450 x D325 x H600	W500 x D325 x H600	W600 x D325 x H600	W800 x D325 x H600	W900 x D325 x H600	W1000 x D325 x H600	W1200 x D325 x H600

Wall Open Shelving Units- 720mm High, 1# Internal Adjustable Height Shelf								
WO37 1# Internal Shelf	WO47 1# Internal Shelf	WO457 1# Internal Shelf	WO57 1# Internal Shelf	WO67 1# Internal Shelf	WO87 1# Internal Shelf	WO97 1# Internal Shelf	WO107 1# Internal Shelf	WO127 1# Internal Shelf
								
W300 x D325 x H720	W400 x D325 x H720	W450 x D325 x H720	W500 x D325 x H720	W600 x D325 x H720	W800 x D325 x H720	W900 x D325 x H720	W1000 x D325 x H720	W1200 x D325 x H720





Wall Open Shelving Units- 900mm High, 2# Internal Adjustable Height Shelf								
WO39 2# Internal Shelves	WO49 2# Internal Shelves	WO459 2# Internal Shelves	WO59 2# Internal Shelves	WO69 2# Internal Shelves	WO89 2# Internal Shelves	WO99 2# Internal Shelves	WO109 2# Internal Shelves	WO129 2# Internal Shelves
								
W300 x D325 x H900	W400 x D325 x H900	W450 x D325 x H900	W500 x D325 x H900	W600 x D325 x H900	W800 x D325 x H900	W900 x D325 x H900	W1000 x D325 x H900	W1200 x D325 x H900

Wall Straight Corner Display Unit- Single Door H300			
WO83C L/R Open Unit	WO93C L/R Open Unit	WO103C L/R Open Unit	WO123C L/R Open Unit
			
W800 x D325 x H300	W900 x D325 x H300	W1000 x D325 x H300	W1200 x D325 x H300





WO L Corner
WO83LC L/R Open Unit

W835/835 x D325 x H300

Wall Straight Corner Display Unit- Single Door H600			
WO86C L/R	WO96C L/R	WO106C L/R	WO126C L/R
			
W800 x D325 x H600	W900 x D325 x H600	W1000 x D325 x H600	W1200 x D325 x H600

WO L Corner
WO86LC L/R

W835/835 x D325 x H600



Wall Straight Corner Display Unit- Single Door H720			
WO87C L/R	WO97C L/R	WO107C L/R	WO127C L/R
			
W800 x D325 x H720	W900 x D325 x H720	W1000 x D325 x H720	W1200 x D325 x H720



WO L Corner
WO87LC L/R

W835/835 x D325 x H720



Wall Straight Corner Display Unit- Single Door H900			
WO89C L/R	WO99C L/R	WO109C L/R	WO129C L/R
			
W800 x D325 x H900	W900 x D325 x H900	W1000 x D325 x H900	W1200 x D325 x H900



WO L Corner
WO89LC L/R

W835/835 x D325 x H900



Accessories



Base Unit End Panels- H882		
EB105	EB106	EB107
		
W20x D500 x H882	W20x D600 x H882	W20x D700 x H882





Mid Height Unit End Panels- H1325		
EB115	EB116	EB117
		
W20x D700 x H1325	W20x D700 x H1325	W20x D700 x H1325







Tall Unit End Panels- H2092		
EB125	EB126	EB127
		
W20x D500 x H2092	W20x D600 x H2092	W20x D700 x H2092



Tall Unit End Panels- H2392		
EB135	EB136	EB137
		
W20x D700 x H2392	W20x D700 x H2392	W20x D700 x H2392

Integrated Appliance Doors		
AD47	AD57	AD67
		
W395x D20 x H730	W495x D20 x H730	W595x D20 x H730

Integrated Appliance Doors with False Drawer		
AD47F	AD57F	AD67F
		
W395x D20 x H730	W495x D20 x H730	W595x D20 x H730

Wall Unit End Panels			
EW103	EW106	EW107	EW109
			
W20x D325 x H300	W20x D325x H600	W20x D325 x H720	W20x D325 x H900

Filter Panels						
F300	F600	F720	F900	F1325	F2092	F2392
						
W150 x H300	W150 x H600	W150 x H720	W150 x H900	W150 x H1325	W150 x H2092	W150 x H2392

Plinths & Pelmets	
P10	PP10
Plinth	Pelmet
	
W2500x D20 x H144	W1000 x D50x H50

TECHNICAL DETAILS

GET A QUOTATION

BACK

EXPLODED VIEW

CROSS SECTION

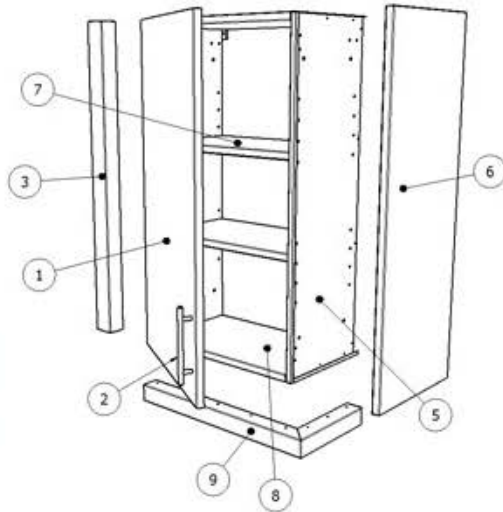

WALL CABINETS

1. Hinged Door (available left or right handed)
2. Bar type pull handle
3. Filler panels (req'd if unit is the last cabinet in a run finishing against a wall or if it is the last cabinet in a run adjoining adjacent units to form an 'L' shaped or 'U' shaped run)
4. Cabinet hung on wall with adjustable fixing brackets (not shown)
5. Exposed sides of unit unfinished (when visible, filler/end panels will be required)
6. Decorative end panel (req'd if unit is hung on its own or is last unit at the end of a run)
7. Internal centre adjustable shelf
8. Internal base shelf
9. Valance panel (required if units are having lighting fitted underneath)

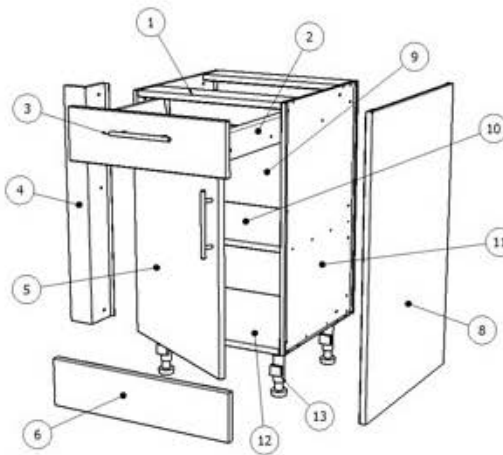

BASE CABINETS

1. Supports for securing worktop
2. Drawer assembly with self closing runners
3. Bar type pull handles
4. Filler panels (req'd if unit is the last cabinet in a run finishing against a wall or if it is the last cabinet in a run adjoining adjacent units to form an 'L' shaped or 'U' shaped run)
5. Hinged door (available left or right handed)
6. Removable plinth panel
7. Cabinet secured back to wall with adjustable fixing brackets (not shown)
8. Decorative end panel (req'd if unit stands on its own or is last unit at the end of a run)
9. Removable rear panel for access to services etc
10. Internal adjustable shelf
11. Exposed sides of unit unfinished (when visible filler / end panels will be required)
12. Internal fixed shelf
13. Height adjustable legs

TECHNICAL DETAILS

GET A QUOTATION

BACK

TECHNICAL DETAILS

CROSS SECTION

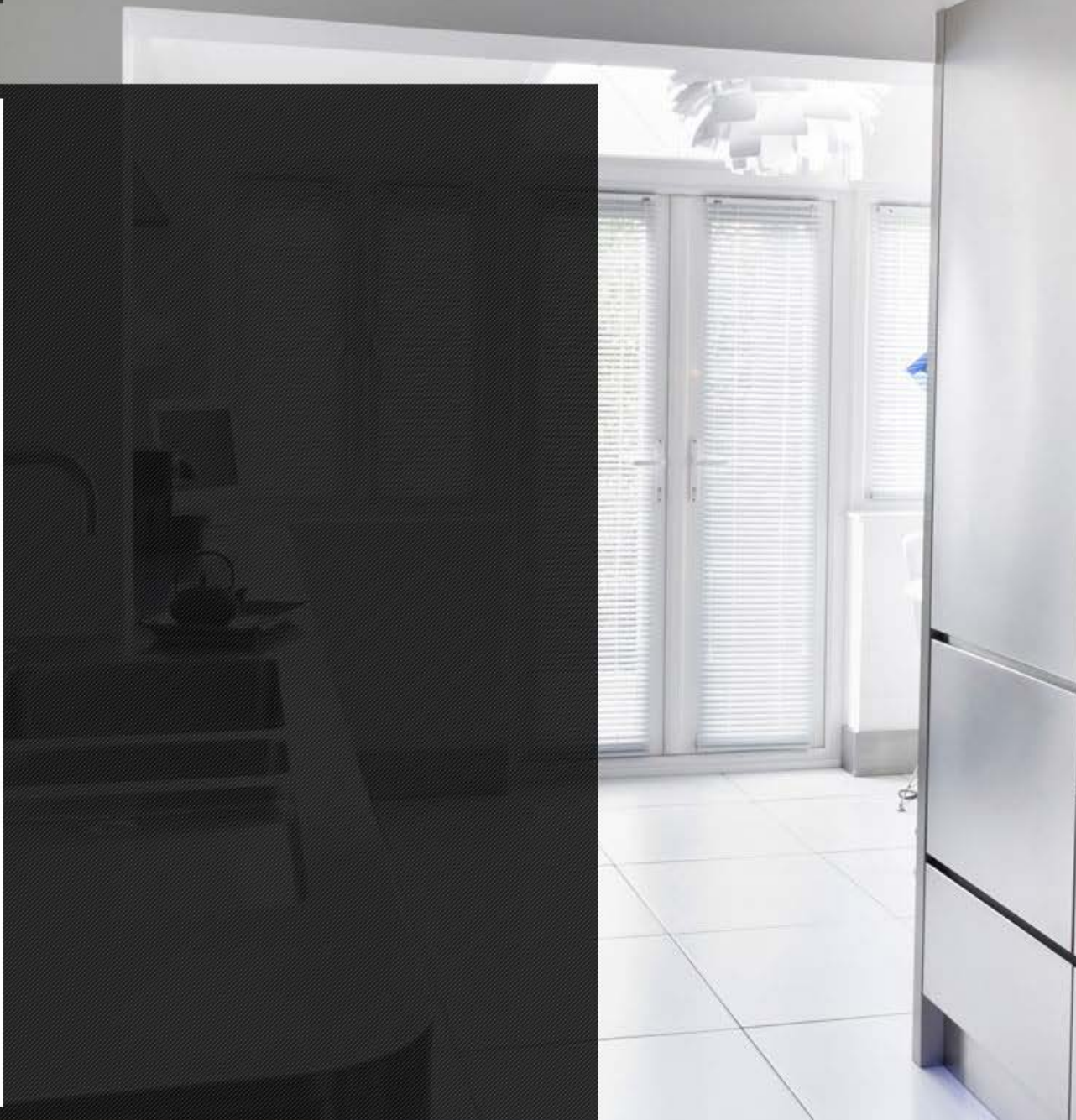
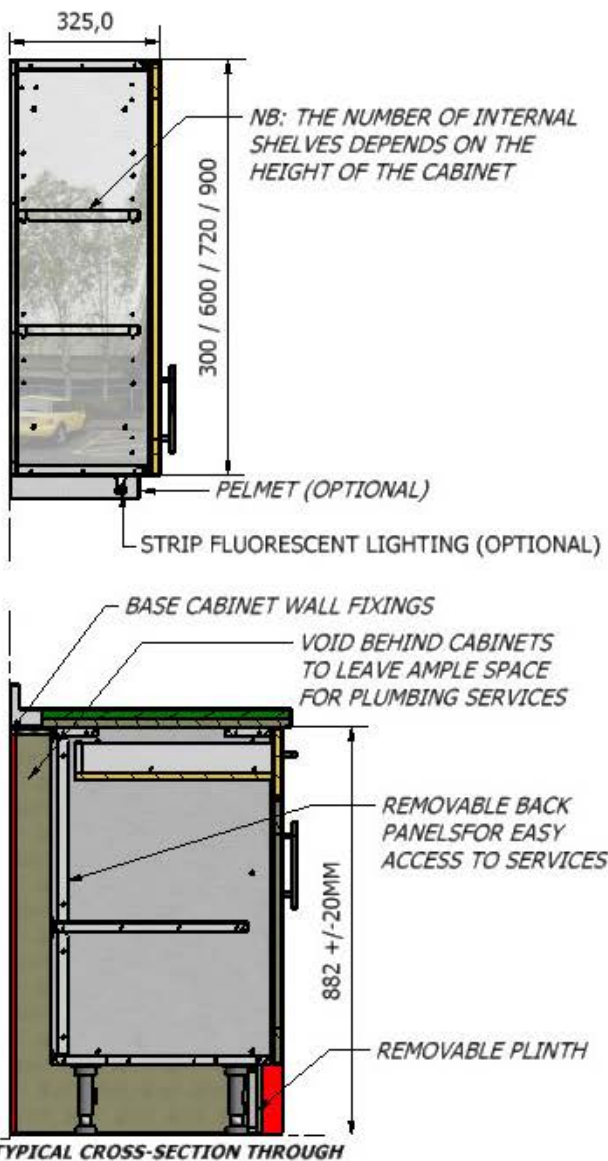

Name	MR J SMITH		
Company Name	If applicable		
Address	THE PLACE, No.1 The Lane, Sometown, Somewhere		
Postcode	254 548	Email	MAIL@MAIL.COM
Telephone No	118 118	Mobile	Fax
Project Ref	NEW ST/STEEL KITCHEN		

Services Required	Template, Supply & Install	<input checked="" type="radio"/>
	Template, Supply & Delivery Only	<input type="radio"/>
	Supply & Collection Only	<input type="radio"/>
	Supply & Delivery Only	<input type="radio"/>
Delivery / Installation Address (if different)		

CAVENDISH EQUIPMENT LIMITED

Tel No. 01992 767105
 Fax No. 01992 716927
 sales@cavendishequipment.co.uk

Specialists in the manufacture and installation of stainless steel kitchens, including worktops, cabinets & splashbacks

Cabinet Specification			
Item	Description	Qty	Model
1	END PANEL	1	EB10
2	APPLIANCE HOUSING	1	TH65DOC
3	WALL CUPB'D-SGL DOOR	1	W66L
4	WALL CUPB'D-DBL DOOR	1	W126
5	FILLER PANEL	1	F600
6	PELMET- L1860MM	1	N/A
7	TAP- BY OTHERS	1	TBA
8	WORKTOP- SEE ATTACHED	1	N/A
9	FILLER PANEL	1	F732
10	BASE CUPB'D+DRAWER	1	D65SL
11	DRAWER PACK-3	1	DD65-3
12	END PANEL	1	EB10
13	PLINTH- L2480MM	1	N/A
14			
15			
16			
17			
18			
19			
20			
21			
22			
23			
24			
25			
26			
27			
28			
29			
30			

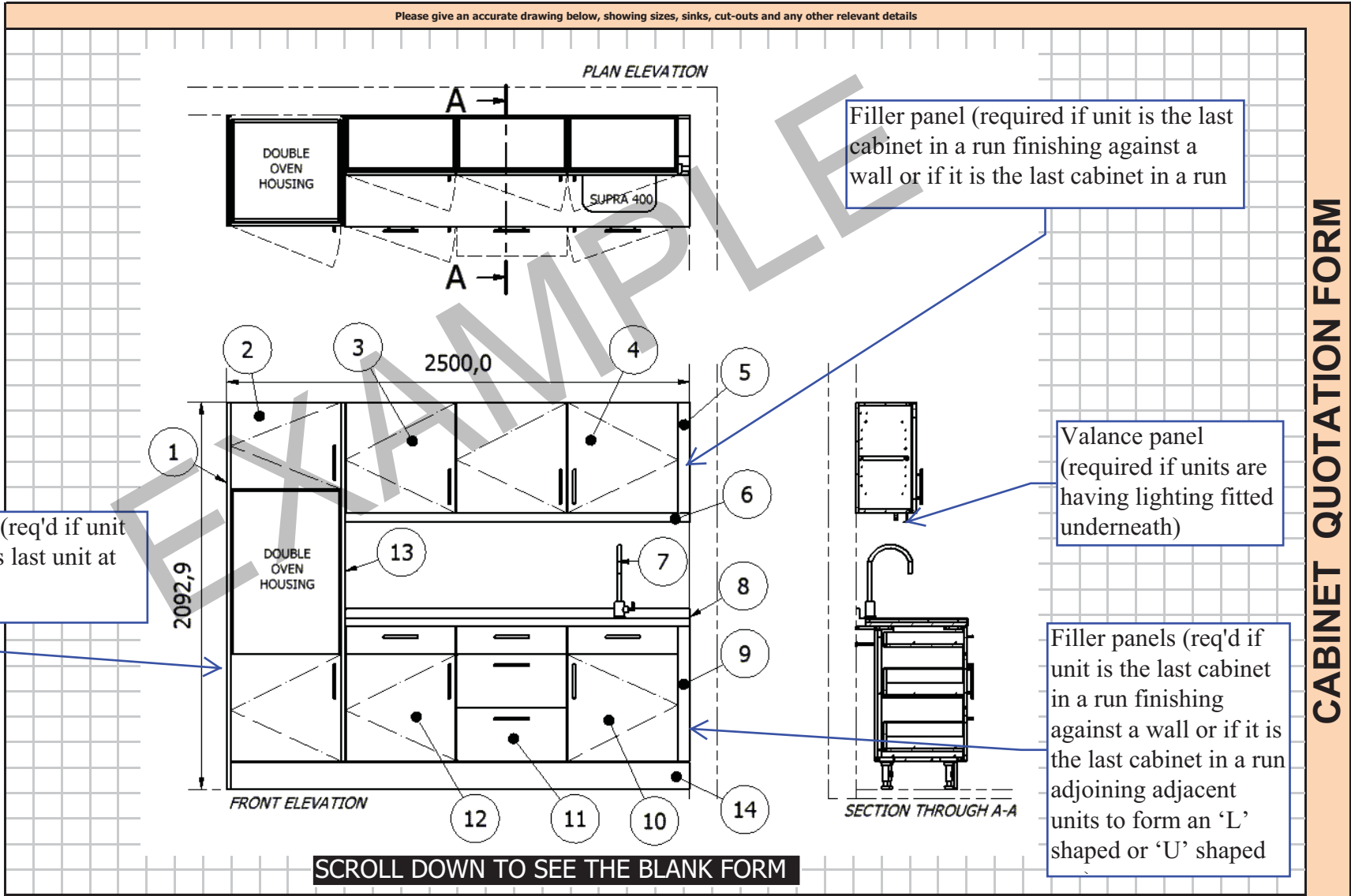

SCROLL DOWN TO SEE THE BLANK FORM

Additional Information

GROUND FLOOR, GOOD ACCESS + PARKING

CABINET QUOTATION FORM

Name			
Company Name	<i>If applicable</i>		
Address			
Postcode		Email	
Telephone No		Mobile	Fax
Project Ref			

Services Required	Template, Supply & Install
	Template, Supply & Delivery Only
	Supply & Collection Only
	Supply & Delivery Only
Delivery / Installation Address (if different)	

CAVENDISH EQUIPMENT LIMITED
 Tel No. 01992 767105
 Fax No. 01992 716927
 sales@cavendishequipment.co.uk
 Specialists in the manufacture and installation of stainless steel kitchens, including worktops, cabinets & splashbacks

Cabinet Specification ?			
Item	Description	Qty	Model
1			
2			
3			
4			
5			
6			
7			
8			
9			
10			
11			
12			
13			
14			
15			
16			
17			
18			
19			
20			
21			
22			
23			
24			
25			
26			
27			
28			
29			
30			
Additional Information			

Please give an accurate drawing below, showing sizes, sinks, cut-outs and any other relevant details

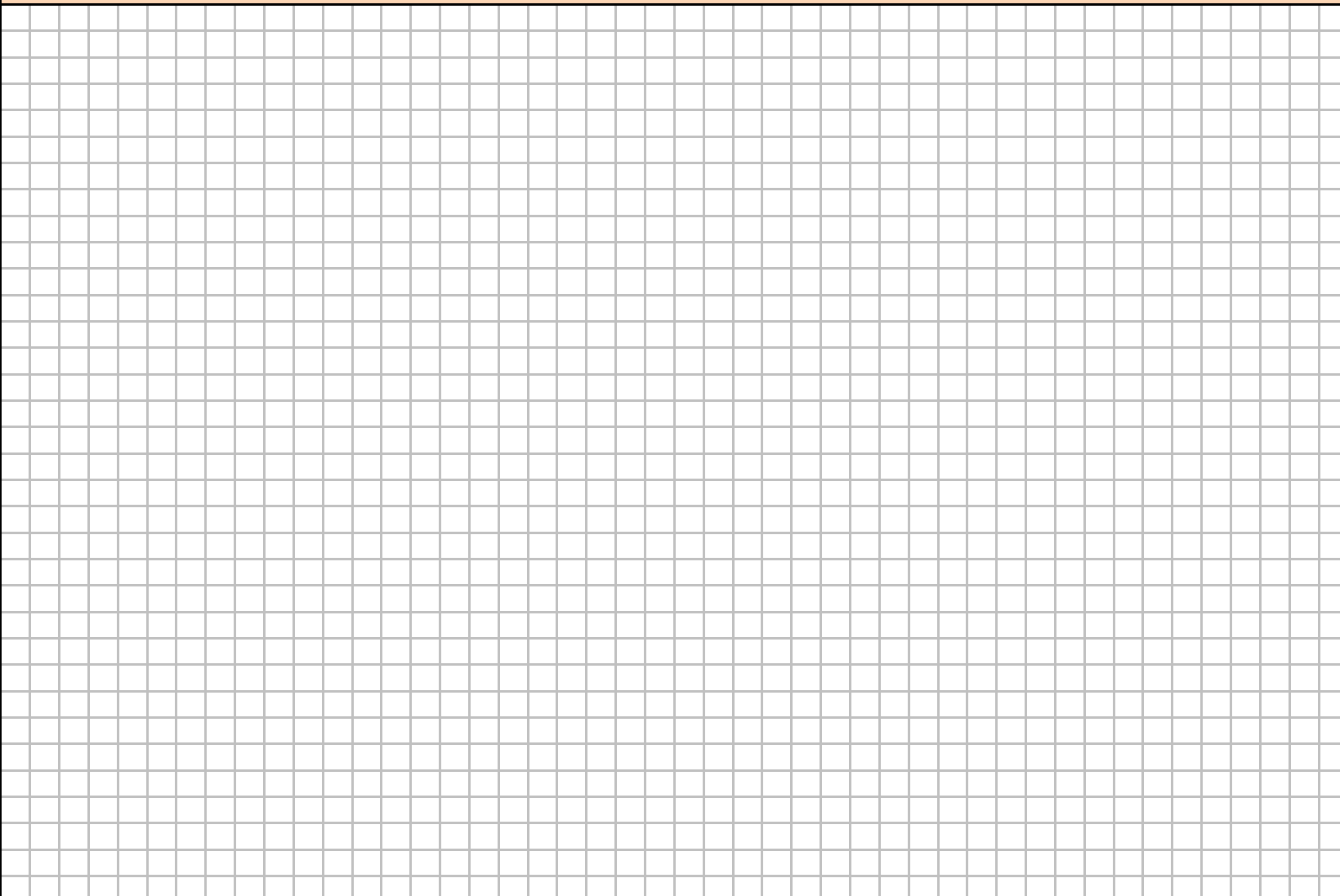

CABINET QUOTATION FORM

Cavendish Equipment established in 1967, are market leaders in the manufacture and installation of high quality stainless steel kitchens.

We manufacture a wide range of stainless steel products including worktops, splashbacks and cabinets to suit both the domestic and commercial environments. We are also able to offer a bespoke service to suit your individual needs. Please view our products section to see what is available.

E & OE. Due to a policy of continual product improvement, Cavendish Equipment Ltd. reserves the right to alter specifications and prices without prior notice.

The information and the designs of the products shown here within are the property of Cavendish Equipment Ltd. must not be copied, reproduced or electronically stored in any way without the prior consent of the proprietors Cavendish Equipment Limited. ©

Cavendish Equipment Ltd.
Monro Industrial Estate,
Station Approach,
Waltham Cross,
Hertfordshire,
EN8 7LX

Sales

Tel No. 01992 715 454
Fax No. 01992 716 927
sales @ cavendishequipment.co.uk
www.cavendishequipment.co.uk

Co. Registration 919294

